

IMPROVING THE HADRONIZATION OF QCD CURRENTS IN TAUOLA AND PHOKHARA

Work done in collaboration with D. Gómez-Dumm, A. Pich, J. Portolés

See Phys.Rev.D69:073002,2004 ; AIP Conf.Proc.964:40-46,2007 ; and to appear soon

QCD 08
Montpellier
July 9th 2008

Pablo Roig

Pablo.Roig@ific.uv.es

Instituto de Física Corpuscular

CSIC-UEVEG València (Spain)



SUMMARY:

- **Hadronic decays** of the τ lepton
- **Kühn-Santamaría Model** in **TAUOLA**
- Tools : χ PT, Large N_c , $R\chi T$
- $\tau^- \rightarrow (2K \pi)^- \nu_\tau$ (Gómez Dumm, Pich, Portolés, R. to appear)
- Outlook : $\tau^- \rightarrow (h_1 h_2 h_3)^- \nu_\tau$

SUMMARY:

- **Hadronic decays** of the τ lepton
- **Kühn-Santamaría Model** in **TAUOLA**
- Tools : χ PT, Large N_c , $R\chi T$
- $\tau^- \rightarrow (2K \pi)^- \nu_\tau$ (Gómez Dumm, Pich, Portolés, R. to appear)
- Outlook : $\tau^- \rightarrow (h_1 h_2 h_3)^- \nu_\tau$ $h_1 h_2 h_3 = 3K, 2\pi \eta, K\pi\eta$

HADRONIC DECAYS OF THE τ LEPTON

$$\mathfrak{M} = \frac{G_F}{\sqrt{2}} V_{CKM} \bar{u}(v_\tau) \gamma^\mu (1 - \gamma_5) u(\tau) T_\mu$$

$$T_\mu = \langle \text{Hadrons} | (\mathbf{V}-\mathbf{A})_\mu e^{iS_{\text{QCD}}} | 0 \rangle =$$

$$= \sum_i (\text{Lorentz Structure})^i F_i(Q^2, s_j)$$

$$d\Gamma = \frac{G_F^2}{4M_\tau^2} |V_{CKM}|^2 d\Phi^{(n+1)} L_{\mu\nu} T^\mu T^{\nu*}$$

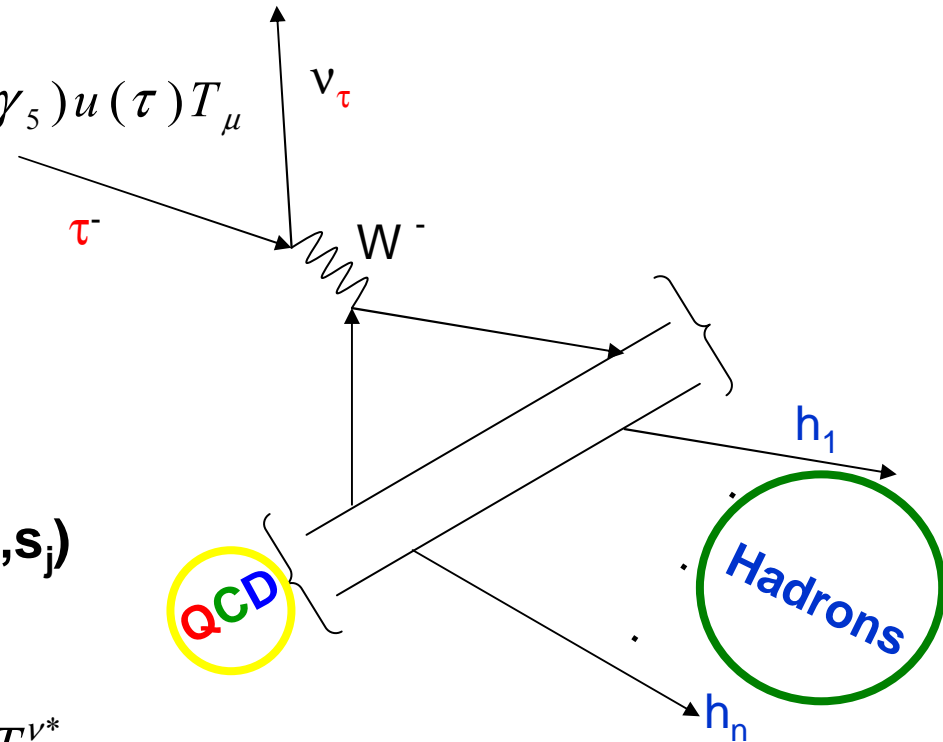

HADRONIC DECAYS OF THE τ LEPTON

$$\mathfrak{M} = \frac{G_F}{\sqrt{2}} V_{CKM} \bar{u}(v_\tau) \gamma^\mu (1 - \gamma_5) u(\tau) T_\mu$$

$$T_\mu = \langle \text{Hadrons} | (\mathbf{V}-\mathbf{A})_\mu e^{iS_{\text{QCD}}} | 0 \rangle =$$

$$= \sum_i (\text{Lorentz Structure})^i F_i(Q^2, s_j)$$

$$d\Gamma = \frac{G_F^2}{4M_\tau^2} |V_{CKM}|^2 d\Phi^{(n+1)} L_{\mu\nu} T^\mu T^{\nu*}$$

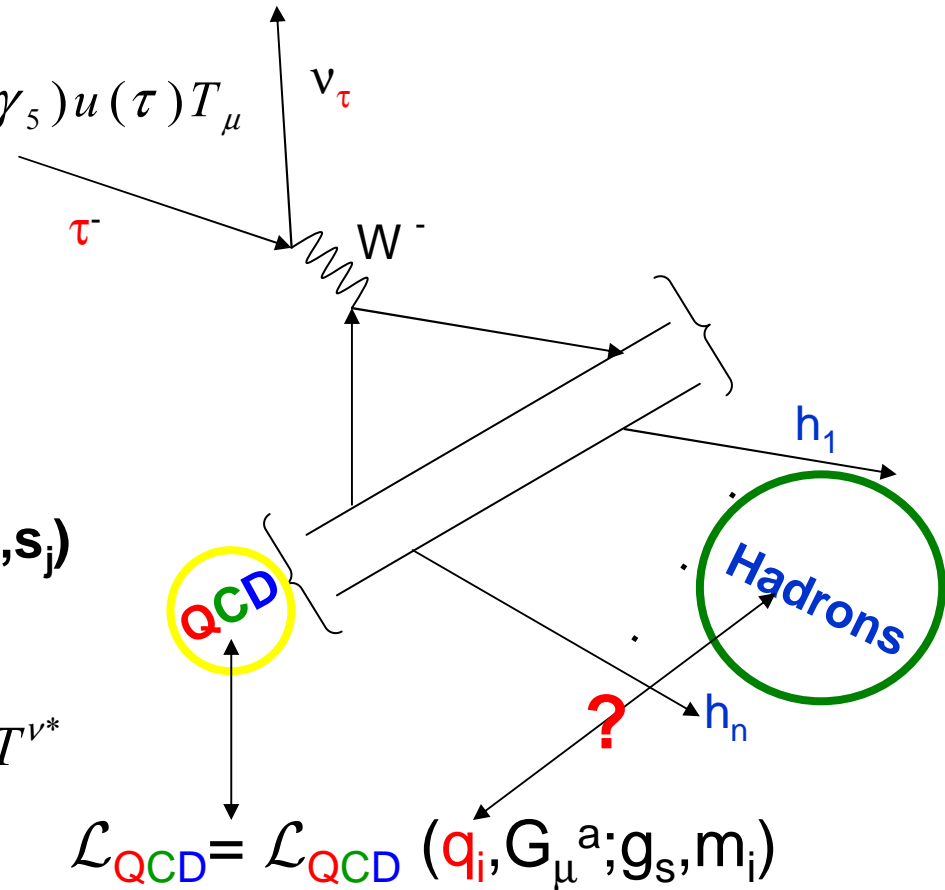

HADRONIZATION OF QCD CURRENTS
Pablo Roig (IFIC)

HADRONIC DECAYS OF THE τ LEPTON

$$\mathfrak{M} = \frac{G_F}{\sqrt{2}} V_{CKM} \bar{u}(v_\tau) \gamma^\mu (1 - \gamma_5) u(\tau) T_\mu$$

$$T_\mu = \langle \text{Hadrons} | (\mathbf{V}-\mathbf{A})_\mu e^{iS_{\text{QCD}}} | 0 \rangle =$$

$$= \sum_i (\text{Lorentz Structure})^i F_i(Q^2, s_j)$$

$$d\Gamma = \frac{G_F^2}{4M_\tau^2} |V_{CKM}|^2 d\Phi^{(n+1)} L_{\mu\nu} T^\mu T^{\nu*}$$

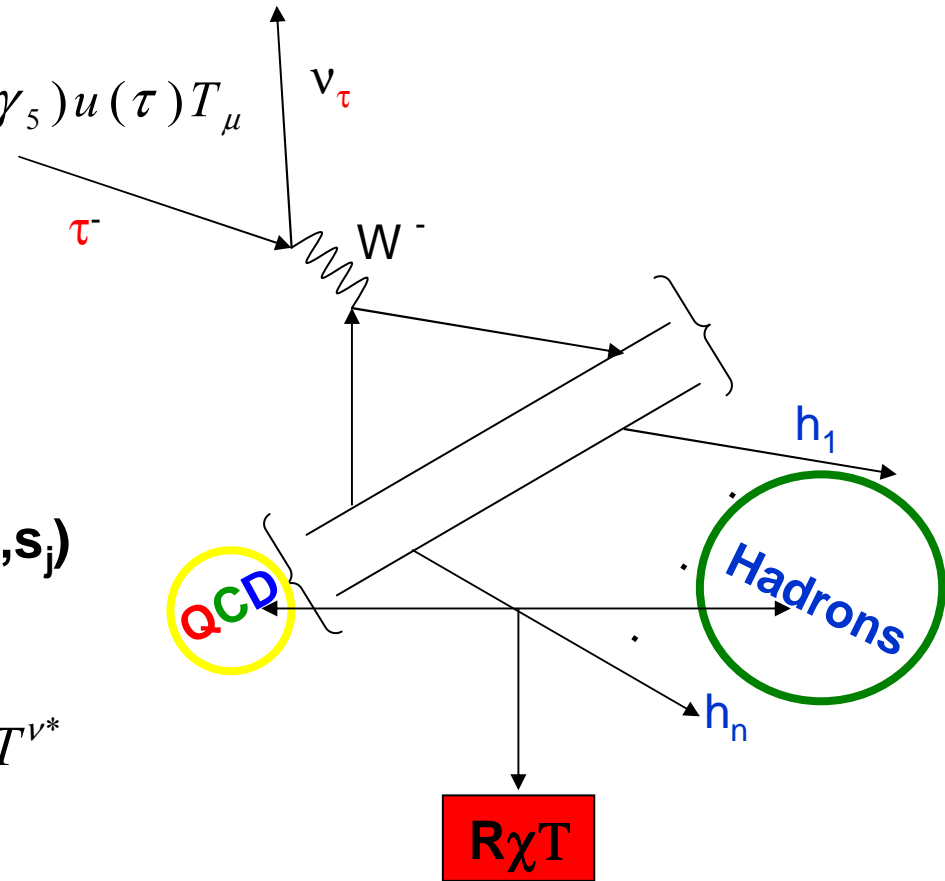

HADRONIZATION OF QCD CURRENTS
Pablo Roig (IFIC)

HADRONIC DECAYS OF THE τ LEPTON

$$\mathfrak{M} = \frac{G_F}{\sqrt{2}} V_{CKM} \bar{u}(v_\tau) \gamma^\mu (1 - \gamma_5) u(\tau) T_\mu$$

$$\tau^- \rightarrow h_1(p_1) h_2(p_2) h_3(p_3) \nu_\tau$$

$$(p_1 + p_2 + p_3)^\mu = Q^\mu, \quad V_{1\mu} = \left(g_{\mu\nu} - \frac{Q_\mu Q_\nu}{Q^2} \right) (p_2 - p_1)^\nu$$

$$T_\mu = V_{1\mu} F_1 + V_{2\mu} F_2 + Q_\mu F_P + i \epsilon_{\mu\nu\rho\sigma} p_1^\nu p_2^\rho p_3^\sigma F_V$$

$$\frac{d\Gamma}{dQ^2} = \frac{G_F^2 |V_{CKM}|^2}{128(2\pi)^5 M_\tau^3} \int ds dt f(I_{0^-}, I_{1^+}, I_{1^-})$$

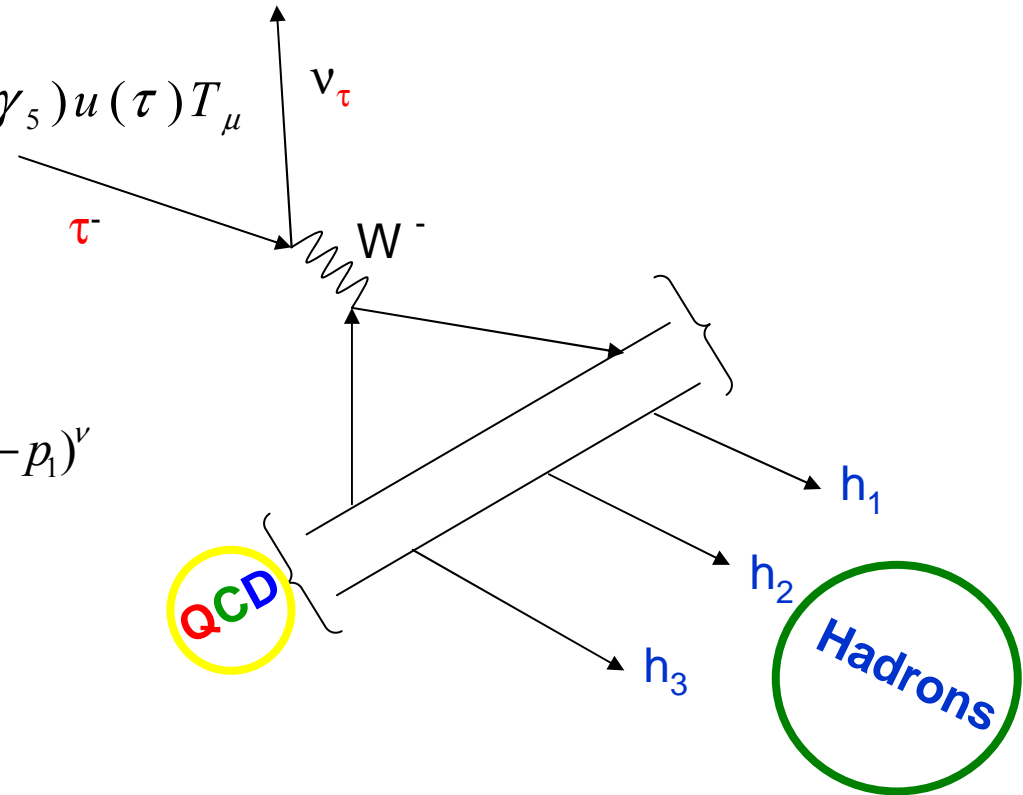

HADRONIZATION OF QCD CURRENTS

Pablo Roig (IFIC)

KÜHN-SANTAMARÍA MODEL

(Kühn-Santamaría '90)

KS



χ PT $\mathcal{O}(p^2)$



χ PT $\mathcal{O}(p^4)$



Vector Meson Dominance

(Sakurai '69, Kühn & Wagner '84, Pich '87)



Asymptotic behaviour ruled by QCD

(Brodsky-Farrar '73, B-Lepage '80)

?

$$BW_R(x^2) = \frac{M_R^2}{M_R^2 - x^2 - i\sqrt{x^2} \Gamma_R(x^2)} \quad (\text{Gounaris-Sakurai '68})$$

TOOLS: EFFECTIVE FIELD THEORIES

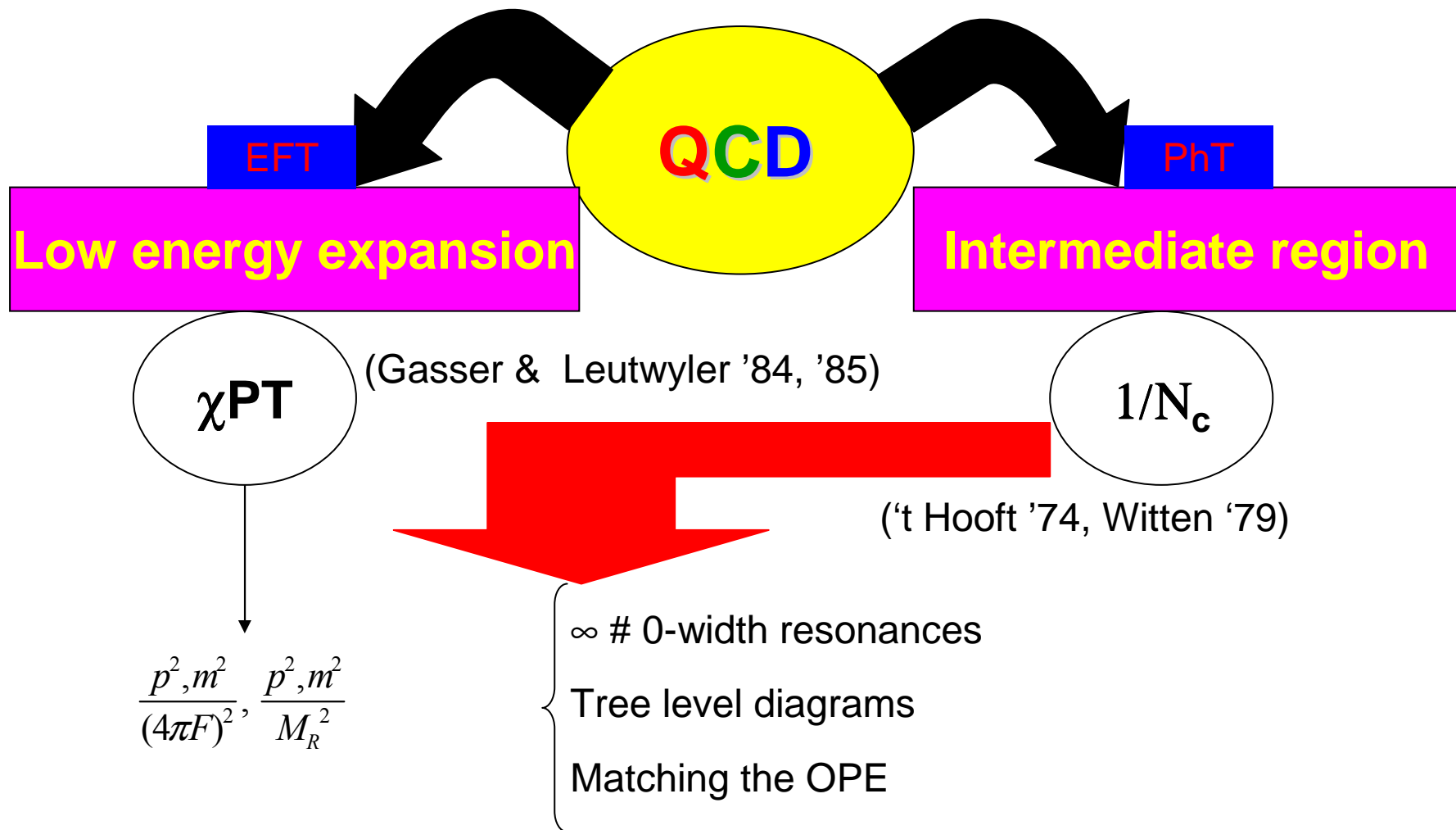

HADRONIZATION OF QCD CURRENTS

Pablo Roig (IFIC)

TOOLS: EFFECTIVE FIELD THEORIES

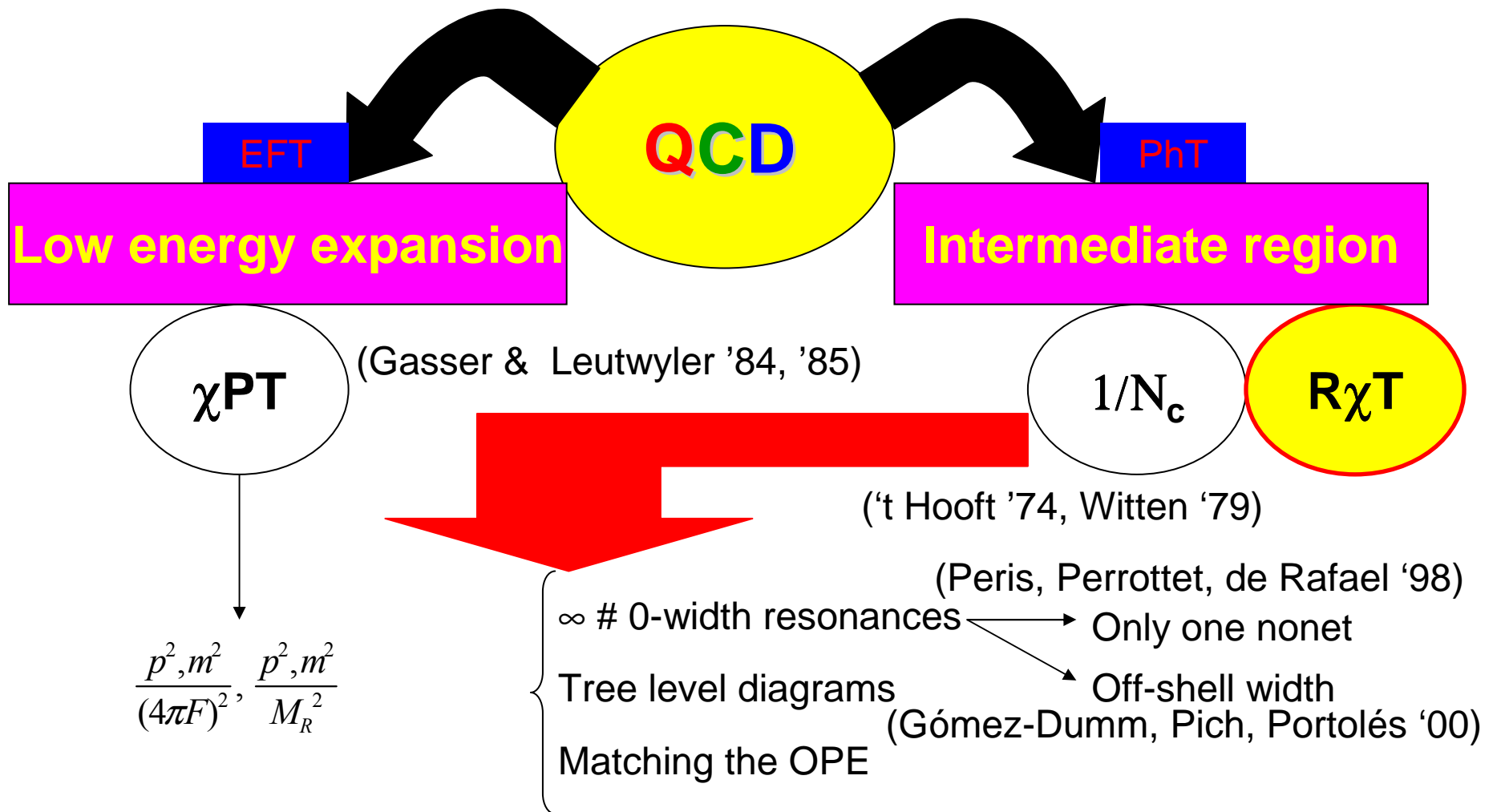

HADRONIZATION OF QCD CURRENTS

Pablo Roig (IFIC)

R_χT APPLIED

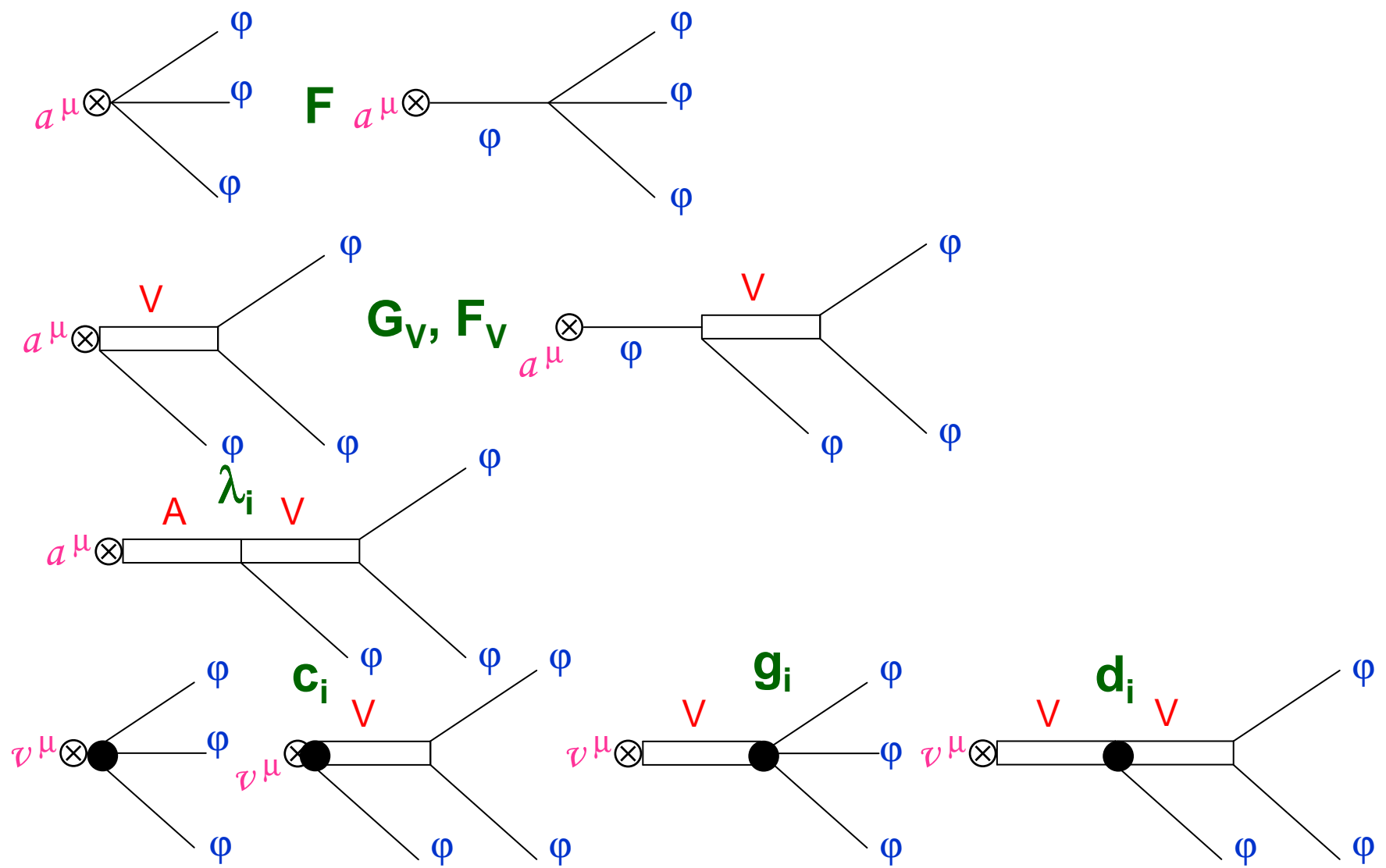

QCD 08 Montpellier

HADRONIZATION OF QCD CURRENTS
Pablo Roig (IFIC)

R_χT APPLIED

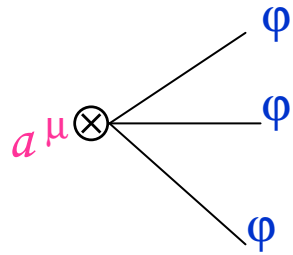

F

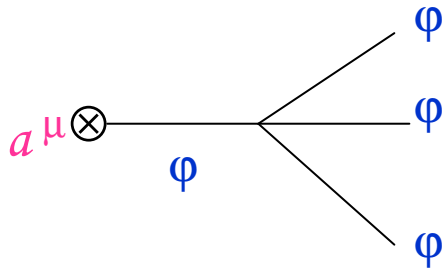

23 unknown couplings

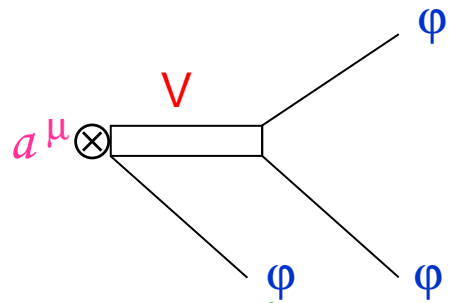

G_V, F_V

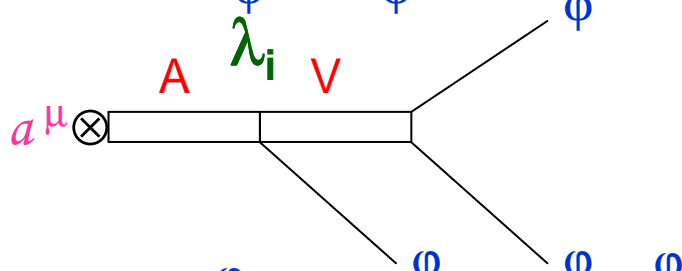
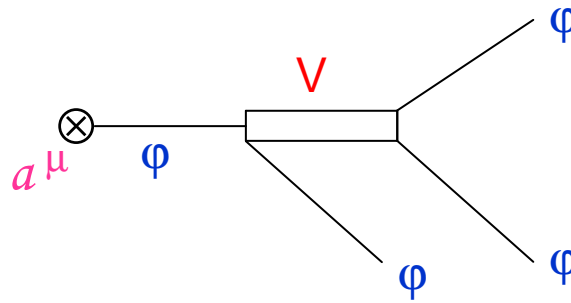

G_i

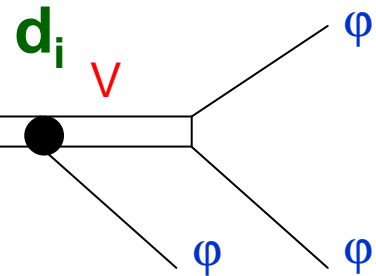
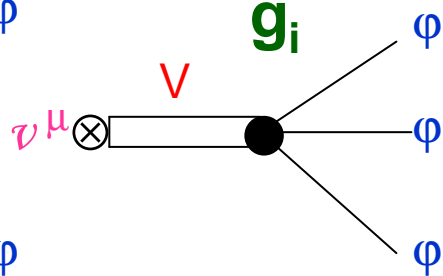
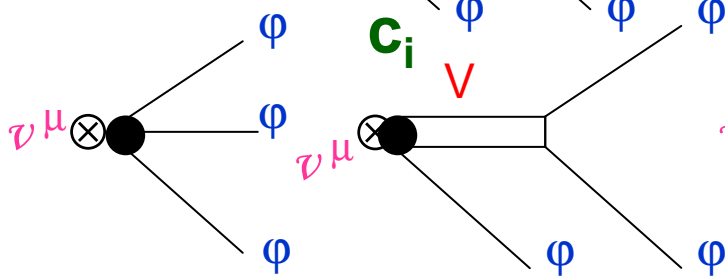

HADRONIZATION OF QCD CURRENTS

QCD 08 Montpellier

Pablo Roig (IFIC)

$$\tau^- \rightarrow (2K \pi)^- \nu_{\tau}$$

The phenomenological approach of **KS-like** works (Finkemeier and Mirkes '95, '96) does not include all possible contributions for the exchanged resonances and depends noticeably on the excited *resonance parameters*.

$$\tau^- \rightarrow (2K \pi)^- \nu_{\tau}$$

The phenomenological approach of **KS-like** works (Finkemeier and Mirkes '95, '96) does not include all possible contributions for the exchanged resonances and depends noticeably on the excited *resonance parameters*.

CLEO (Liu '03, CLEO '04) could not fit their data using **KS** expressions and reshaped the model violating the normalization of the WZ term (i.e. low-energy **QCD**).

$$\tau^- \rightarrow (2K \pi)^- \nu_{\tau}$$

BaBar has recently (BaBar '07) published very precise data on $e^+e^- \rightarrow KK \pi/\eta$ using **ISR** events. Furthermore, their Dalitz-plot fit has allowed to separate cleanly the $l=0,1$ contributions.

Assuming **CVC** and comparing to **ALEPH '99** allows to derive $(\Gamma_V/\Gamma_{\tau}) = 0.167 \pm 0.024$ in $\tau^- \rightarrow (KK \pi)^- \nu_{\tau}$. Under **CVC** one can relate e^+e^- data to the τ decay.
(Davier, Descotes-Genon, Höcker, Malaescu, Zhang '08)

$$\tau^- \rightarrow (2K \pi)^- \nu_{\tau}$$

BaBar has recently (BaBar '07) published very precise data on $e^+e^- \rightarrow KK \pi/\eta$ using **ISR** events. Furthermore, their Dalitz-plot fit has allowed to separate cleanly the $l=0,1$ contributions.

Assuming **CVC** and comparing to **ALEPH '99** allows to derive $(\Gamma_V/\Gamma_{\tau}) = 0.167 \pm 0.024$ in $\tau^- \rightarrow (KK \pi)^- \nu_{\tau}$. Under **CVC** one can relate e^+e^- data to the τ decay.

(Davier, Descotes-Genon, Höcker, Malaescu, Zhang '08)

Assumptions of this procedure: SU(2) symmetry

$$K^* \gg \rho, \omega, \phi$$

Interferences are negligible

$$\tau^- \rightarrow (2K \pi)^- \nu_{\tau}$$

BaBar has recently (BaBar '07) published very precise data on $e^+e^- \rightarrow KK \pi/\eta$ using **ISR** events. Furthermore, their Dalitz-plot fit has allowed to separate cleanly the $l=0,1$ contributions.

Assuming **CVC** and comparing to **ALEPH '99** allows to derive $(\Gamma_V/\Gamma_T) = 0.167 \pm 0.024$ in $\tau^- \rightarrow (KK \pi)^- \nu_{\tau}$. Under **CVC** one can relate e^+e^- data to the τ decay.

(Davier, Descotes-Genon, Höcker, Malaescu, Zhang '08)

Assumptions of this procedure: SU(2) symmetry 

$K^* \gg \rho, \omega, \phi$ 

Interferences are negligible

$$\tau^- \rightarrow (2K \pi)^- \nu_{\tau}$$

BaBar has recently (BaBar '07) published very precise data on $e^+e^- \rightarrow KK \pi/\eta$ using **ISR** events. Furthermore, their Dalitz-plot fit has allowed to separate cleanly the $l=0,1$ contributions.

Assuming **CVC** and comparing to **ALEPH '99** allows to derive $(\Gamma_V/\Gamma_{\tau}) = 0.167 \pm 0.024$ in $\tau^- \rightarrow (KK \pi)^- \nu_{\tau}$. Under **CVC** one can relate e^+e^- data to the τ decay.

(Davier, Descotes-Genon, Höcker, Malaescu, Zhang '08)

Assumptions of this procedure: SU(2) symmetry 

$K^* \gg \rho, \omega, \phi$ 

Interferences are negligible 



Error of this simplification $\sim 30\%$ both in **KS** approach and in ours

HADRONIZATION OF QCD CURRENTS
Pablo Roig (IFIC)

$$\tau^- \rightarrow (2K \pi)^- \nu_{\tau}$$

Our work:

(Gómez Dumm, Pich, Portolés, R. to appear)

1. Computation of the involved process within $R\chi T$ (23-8 = 15 couplings).
2. Brodsky-Lepage behaviour demanded to the Form Factors (15-9 = 6 couplings).
3. Computation and fit to $Br(\omega \rightarrow 3\pi)$ completing (Pich, Portolés, Ruiz-Femenía '03). Use of some constraints from this work for $\langle VVP \rangle$ (6-3 = 3 couplings).
4. **Axial-form factor fixed** by $\tau \rightarrow 3\pi \nu_{\tau}$ (3-1 = 2 couplings). (Gómez-Dumm, Pich, Portolés '04) (Cirigliano, Ecker, Eidemüller, Pich, Portolés '04).
5. **Vector-form factor fixed** thanks to $br(\tau \rightarrow K^+ K^- \pi \nu_{\tau})$ and $br(\tau \rightarrow K^- K^0 \pi^0 \nu_{\tau})$ (2-2 = 0 couplings).

$$\tau^- \rightarrow (2K \pi)^- \nu_{\tau}$$

Our work:

(Gómez Dumm, Pich, Portolés, R. to appear)

1. Computation of the involved process within $R\chi T$ (23-8 = 15 couplings).
2. Brodsky-Lepage behaviour demanded to the Form Factors (15-9 = 6 couplings).
3. Computation and fit to $Br(\omega \rightarrow 3\pi)$ completing (Pich, Portolés, Ruiz-Femenía '03). Use of some constraints from this work for $\langle VVP \rangle$ (6-3 = 3 couplings).
4. **Axial-form factor fixed** by $\tau \rightarrow 3\pi \nu_{\tau}$ (3-1 = 2 couplings). (Gómez-Dumm, Pich, Portolés '04) (Cirigliano, Ecker, Eidemüller, Pich, Portolés '04).
5. **Vector-form factor fixed** thanks to $br(\tau \rightarrow K^+ K^- \pi \nu_{\tau})$ and $br(\tau \rightarrow K^- K^0 \pi^0 \nu_{\tau})$ (2-2 = 0 couplings).

Hence, we predict: i) the **spectra** of the $KK\pi$ modes

$$ii) (\Gamma_V / \Gamma_T) \sim 0.50$$

(Gómez Dumm, Pich, Portolés, R. to appear)

$$\tau^- \rightarrow K^- K^0 \pi^0 \nu_\tau$$
$$M_A = 1.17 \text{ GeV}, c_4 = -0.058$$

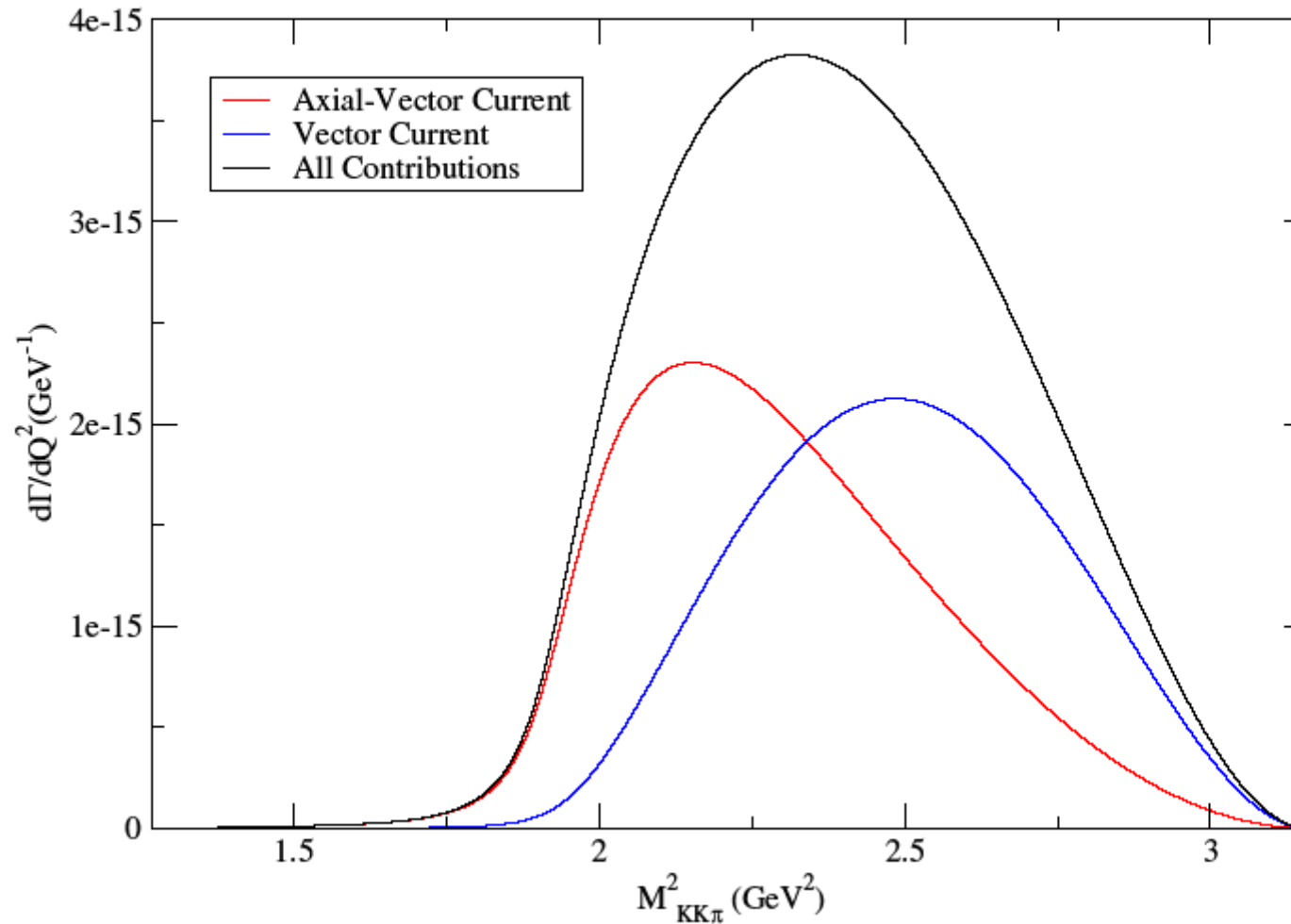

HADRONIZATION OF QCD CURRENTS

Pablo Roig (IFIC)

QCD 08 Montpellier

(Gómez Dumm, Pich, Portolés, R. to appear)

$$\tau^- \rightarrow K^+ K^- \pi^- \nu_\tau$$
$$M_A = 1.17 \text{ GeV}, c_4 = -0.058, g_4 = -0.58$$

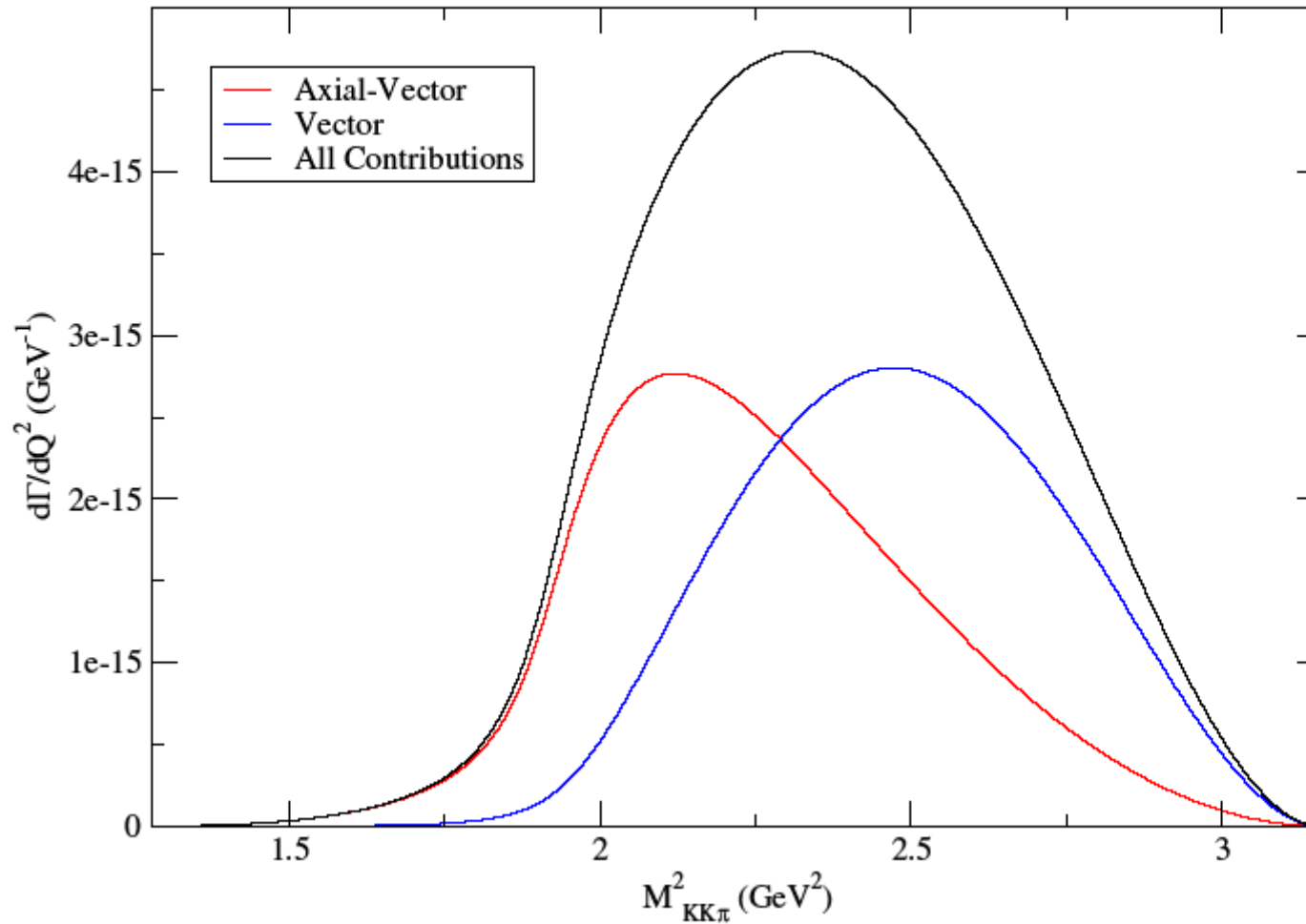

HADRONIZATION OF QCD CURRENTS

Pablo Roig (IFIC)

QCD 08 Montpellier

CONCLUSIONS

- Current analyses of $\tau^- \rightarrow (3\pi^-, K^+K^-\pi^-) \nu_\tau$ data using **TAUOLA** have shown theoretical inconsistencies. We would like to improve the hadronic matrix elements in **TAUOLA**.
- We have studied these decays within **R χ T** with a **Large N_c**-inspired model guided by **QCD**.
- We have improved our off-shell **a₁** width and revisited $\tau^- \rightarrow 3\pi^- \nu_\tau$.
- Using the available experimental data, we have been able to predict the spectra of all **KK π** charge channels.
- Our expressions are easy to extend to the **e⁺e⁻** scattering below 2 GeV and thus may be of use for **PHOKHARA**.
- Our results have been implemented in **SHERPA** (**LHC** and **TEVATRON**) and may be used by the **B-factories**.
- **LHC, BABAR, BELLE, BES...** are promising facilities to test our predictions.
- The future looks even more promising and exciting: **V_{us}, m_s, m _{ν_τ}** and, of course, hadronization of **QCD** currents.

HADRONIZATION OF QCD CURRENTS

Pablo **Roig** (IFIC)

QCD 08 Montpellier

BACKUP

SLIDES

K-S-like works & HADRONIZATION IN TAUOLA

(Finkemeier, Mirkes '95,'96)
 (Finkemeier, Kühn, Mirkes '96)

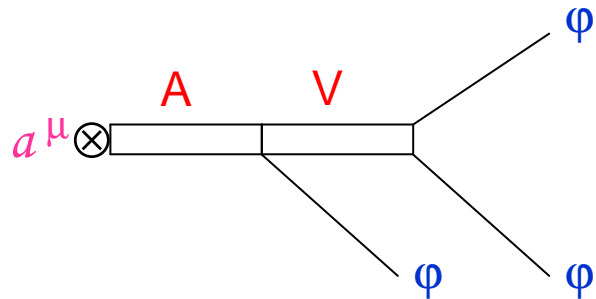

$$\rightarrow V_{1\mu} = \left(g_{\mu\nu} - \frac{Q_\mu Q_\nu}{Q^2} \right) (p_2 - p_1)^\nu$$

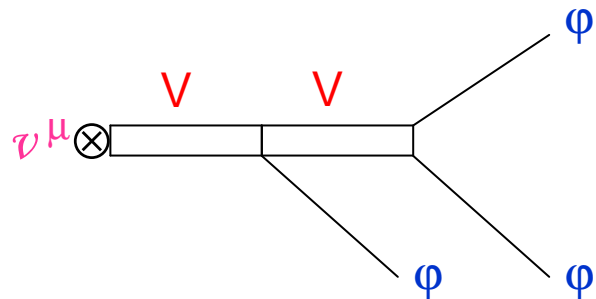

$$\rightarrow i\epsilon_{\mu\nu\rho\sigma} p_1^\nu p_2^\rho p_3^\sigma$$

χ_{1R} & $2R$
 obtained from:

$$\frac{M_{R1}^2}{M_{R1}^2 - x^2 - i\sqrt{x^2} \Gamma_{R1}(x^2)} \frac{M_{R2}^2}{M_{R2}^2 - y^2 - i\sqrt{y^2} \Gamma_{R2}(y^2)}$$

HADRONIZATION OF QCD CURRENTS

Pablo Roig (IFIC)

K-S-like works & HADRONIZATION IN TAUOLA

(Finkemeier, Mirkes '95,'96)
 (Finkemeier, Kühn, Mirkes '96)

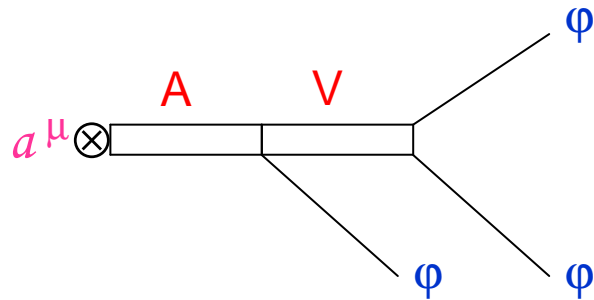

Some allowed $\rho^{0,-}$, K^{*0} contributions are lacking in the modes: $K^+K^-\pi^-$, $K^-K^0\pi^0$, $K^-\pi^+\pi^+$, $K^0\pi^0\pi^-$

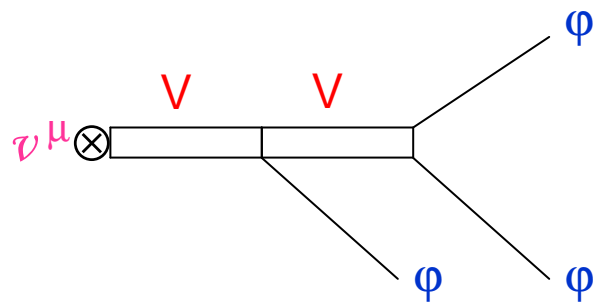

$$M_{\rho'}^{V_\mu} \neq M_{\rho'}^{A_\mu}$$

$$\Gamma_{\rho'}^{V_\mu} \neq \Gamma_{\rho'}^{A_\mu}$$

$$3 \text{ Multiplets}^{V_\mu} \neq 2 \text{ Multiplets}^{A_\mu}$$

χ PT: The low-energy EFT of QCD

(Gasser & Leutwyler '84, '85)

$$\phi(x) = \begin{pmatrix} \frac{\pi^0}{\sqrt{2}} + \frac{\eta_8}{\sqrt{6}} & \pi^+ & K^+ \\ \pi^- & -\frac{\pi^0}{\sqrt{2}} + \frac{\eta_8}{\sqrt{6}} & K^0 \\ K^- & \bar{K}^0 & -\frac{2\eta_8}{\sqrt{6}} \end{pmatrix}$$

Goldstone
Bosons

$$SU(3)_L \otimes SU(3)_R \rightarrow SU(3)_V$$

$$u(x) = \exp\left(\frac{i\phi(x)}{\sqrt{2}F}\right), \quad u_\mu = i\left[u^\dagger(\partial_\mu - ir_\mu)u - u(\partial_\mu - il_\mu)u^\dagger\right]$$

$$\chi = 2B_0(s + ip), \quad \chi_\pm = u^\dagger \chi u^\dagger \pm u \chi u$$

$$f_\pm^{\mu\nu} = u F_L^{\mu\nu} u^\dagger \pm u^\dagger F_R^{\mu\nu} u$$

$$\mathcal{L}_\chi^{(2)} = \frac{F^2}{4} \langle u_\mu u^\mu + \chi_+ \rangle$$

$$X \rightarrow h(g, \Phi) X h(g, \Phi)^\dagger$$

$$\mathcal{L}_\chi^{(4)} = L_1 \langle u_\mu u^\mu \rangle^2 + \dots + L_4 \langle u_\mu u^\mu \rangle \langle \chi_+ \rangle + \dots + L_7 \langle \chi_- \rangle^2 + \dots - iL_9 \langle f_+^{\mu\nu} u_\mu u_\nu \rangle + \dots$$

$$\mathcal{L}_\chi^{(4)} \text{, } WZW \text{ in the odd-intrinsic parity sector}$$

HADRONIZATION OF QCD CURRENTS

Pablo Roig (IFIC)

**Resonances
+ Goldstone
Bosons**

TOOLS : RχT

(Ecker, Gasser, Pich, De Rafael '89)

(Ecker, Gasser, Leutwyler, Pich, De Rafael '89)

$$\mathcal{L}_{R\chi T}^{(P_I=+)} = \mathcal{L}_{\chi}^{(2)} + \mathcal{L}_{V,A}^{kin} + \mathcal{L}_V + \mathcal{L}_A + \mathcal{L}_{VAP};$$

$$\mathcal{L}_V = \frac{F_V}{2\sqrt{2}} \langle V_{\mu\nu} f_+^{\mu\nu} \rangle + \frac{iG_V}{\sqrt{2}} \langle V_{\mu\nu} u^\mu u^\nu \rangle$$

$$\mathcal{L}_A = \frac{F_A}{2\sqrt{2}} \langle A_{\mu\nu} f_-^{\mu\nu} \rangle$$

Antisymmetric tensor formalism

$$V_{\mu\nu}(x) = \begin{pmatrix} \frac{\rho^0}{\sqrt{2}} + \frac{\omega_8}{\sqrt{6}} & \rho^+ & K^{*+} \\ \rho^- & -\frac{\rho^0}{\sqrt{2}} + \frac{\omega_8}{\sqrt{6}} & K^{*0} \\ K^{*-} & \bar{K}^{*0} & -\frac{2\omega_8}{\sqrt{6}} \end{pmatrix}_{\mu\nu}$$

$$\mathcal{L}_{VAP} = \sum_{i=1}^5 \lambda_i O^i(V_{\mu\nu}, A^{\mu\nu}, \phi) = \lambda_1 \langle [V_{\mu\nu}, A^{\mu\nu}] \chi_- \rangle + \dots$$

(Gómez Dumm, Pich, Portolés '04)

VMD

$$\mathcal{L}_{R\chi T}^{(P_I=-)} = \mathcal{L}_{\chi(WZW)}^{(4)} + \mathcal{L}_{VJP} + \mathcal{L}_{VVP} + \mathcal{L}_{VPPP};$$

$$\mathcal{L}_{VJP} = \sum_{i=1}^7 \frac{c_i}{M_V} O^i(V_{\mu\nu}, j^\nu, \partial^\mu \phi) = \frac{c_5}{M_V} \epsilon_{\mu\nu\rho\sigma} \langle \{ \nabla_\alpha V^{\mu\nu}, f_+^{\rho\alpha} \} u^\sigma \rangle + \dots$$

(Ruiz-Femenía, Pich, Portolés '03)

$$\mathcal{L}_{VVP} = \sum_{i=1}^5 d_i O^i(V_{\mu\nu}, V_{\rho\sigma}, \phi) = d_1 \epsilon_{\mu\nu\rho\sigma} \langle \{ V^{\mu\nu}, V^{\rho\alpha} \} \nabla_\alpha u^\sigma \rangle + \dots$$

$$\mathcal{L}_{VPPP} = \sum_{i=1}^5 \frac{g_i}{M_V} O^i(V_{\mu\nu}, \phi) = \frac{g_4}{M_V} \epsilon_{\mu\nu\alpha\beta} \langle \{ V^{\mu\nu}, u^\alpha u^\beta \} \chi_- \rangle + \dots$$

(Gómez Dumm, Pich, Portolés, R. to appear)

**Resonances
+ Goldstone
Bosons**

TOOLS : RχT

(Ecker, Gasser, Pich, De Rafael '89)

(Ecker, Gasser, Leutwyler, Pich, De Rafael '89) , ...

$$\mathcal{L}_{R\chi T}^{(P_I=+)} = \mathcal{L}_{\chi}^{(2)} + \mathcal{L}_{V,A}^{kin} + \mathcal{L}_V + \mathcal{L}_A + \mathcal{L}_{VAP};$$

$$\mathcal{L}_V = \frac{F_V}{2\sqrt{2}} \langle V_{\mu\nu} f_+^{\mu\nu} \rangle + \frac{iG_V}{\sqrt{2}} \langle V_{\mu\nu} u^\mu u^\nu \rangle$$

$$\mathcal{L}_A = \frac{F_A}{2\sqrt{2}} \langle A_{\mu\nu} f_-^{\mu\nu} \rangle$$

$$\mathcal{L}_{VAP} = \sum_{i=1}^5 \lambda_i O^i(V_{\mu\nu}, A^{\mu\nu}, \phi) = \lambda_1 \langle [V_{\mu\nu}, A^{\mu\nu}] \chi_- \rangle + \dots$$

$$\mathcal{L}_{R\chi T}^{(P_I=-)} = \mathcal{L}_{\chi(WZW)}^{(4)} + \mathcal{L}_{VJP} + \mathcal{L}_{VVP} + \mathcal{L}_{VPPP};$$

$$\mathcal{L}_{VJP} = \sum_{i=1}^7 \frac{c_i}{M_V} O^i(V_{\mu\nu}, j^\nu, \partial^\mu \phi) = \frac{c_5}{M_V} \epsilon_{\mu\nu\rho\sigma} \langle \{ \nabla_\alpha V^{\mu\nu}, f_+^{\rho\alpha} \} u^\sigma \rangle + \dots$$

$$\mathcal{L}_{VVP} = \sum_{i=1}^5 d_i O^i(V_{\mu\nu}, V_{\rho\sigma}, \phi) = d_1 \epsilon_{\mu\nu\rho\sigma} \langle \{ V^{\mu\nu}, V^{\rho\alpha} \} \nabla_\alpha u^\sigma \rangle + \dots$$

$$\mathcal{L}_{VPPP} = \sum_{i=1}^5 \frac{g_i}{M_V} O^i(V_{\mu\nu}, \phi) = \frac{g_4}{M_V} \epsilon_{\mu\nu\alpha\beta} \langle \{ V^{\mu\nu}, u^\alpha u^\beta \} \chi_- \rangle + \dots$$

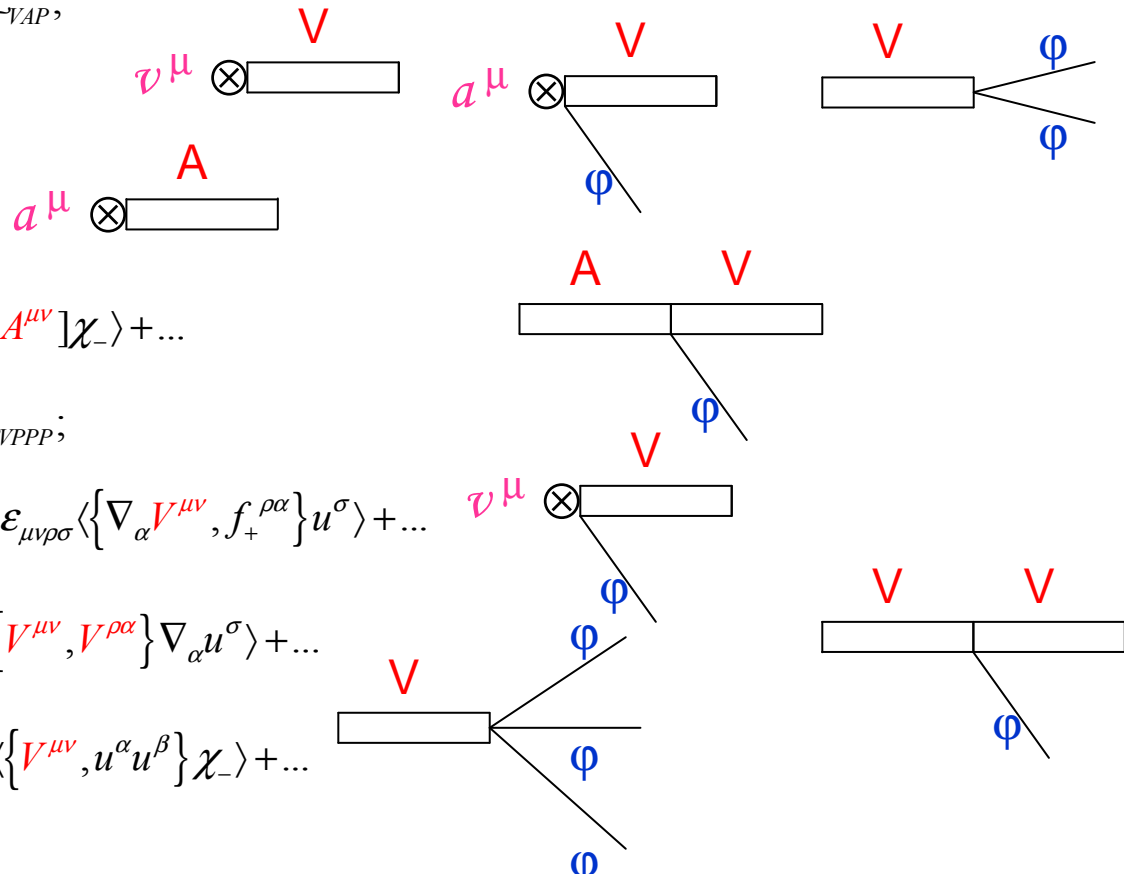

HADRONIZATION OF QCD CURRENTS

Pablo Roig (IFIC)

$e^+ e^- \rightarrow K^* K$
BaBar data

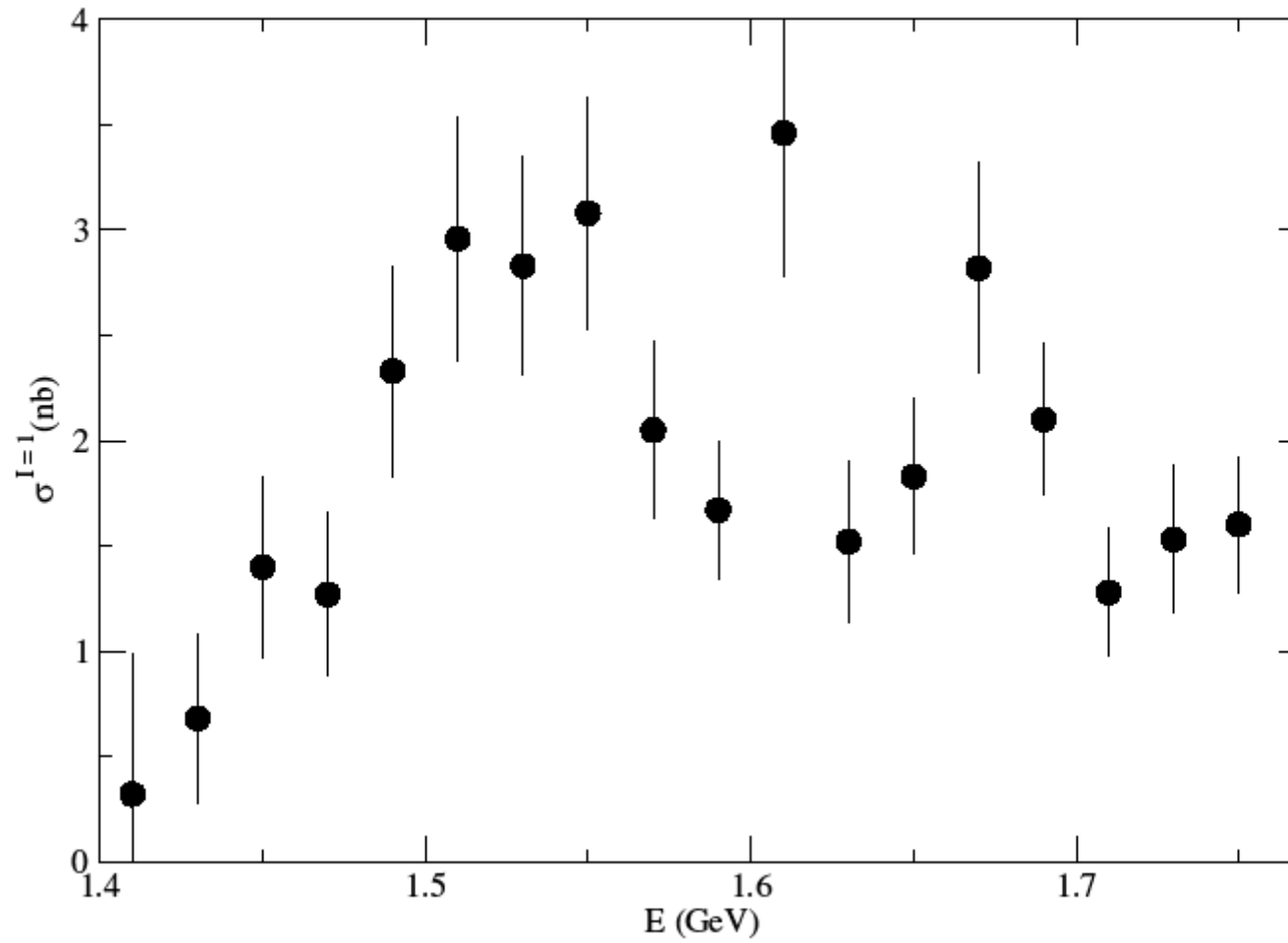

QCD 08 Montpellier

HADRONIZATION OF QCD CURRENTS
Pablo Roig (IFIC)

$$e^+ e^- \rightarrow K^* K$$

$\chi^2/\text{dof} = 0.62$

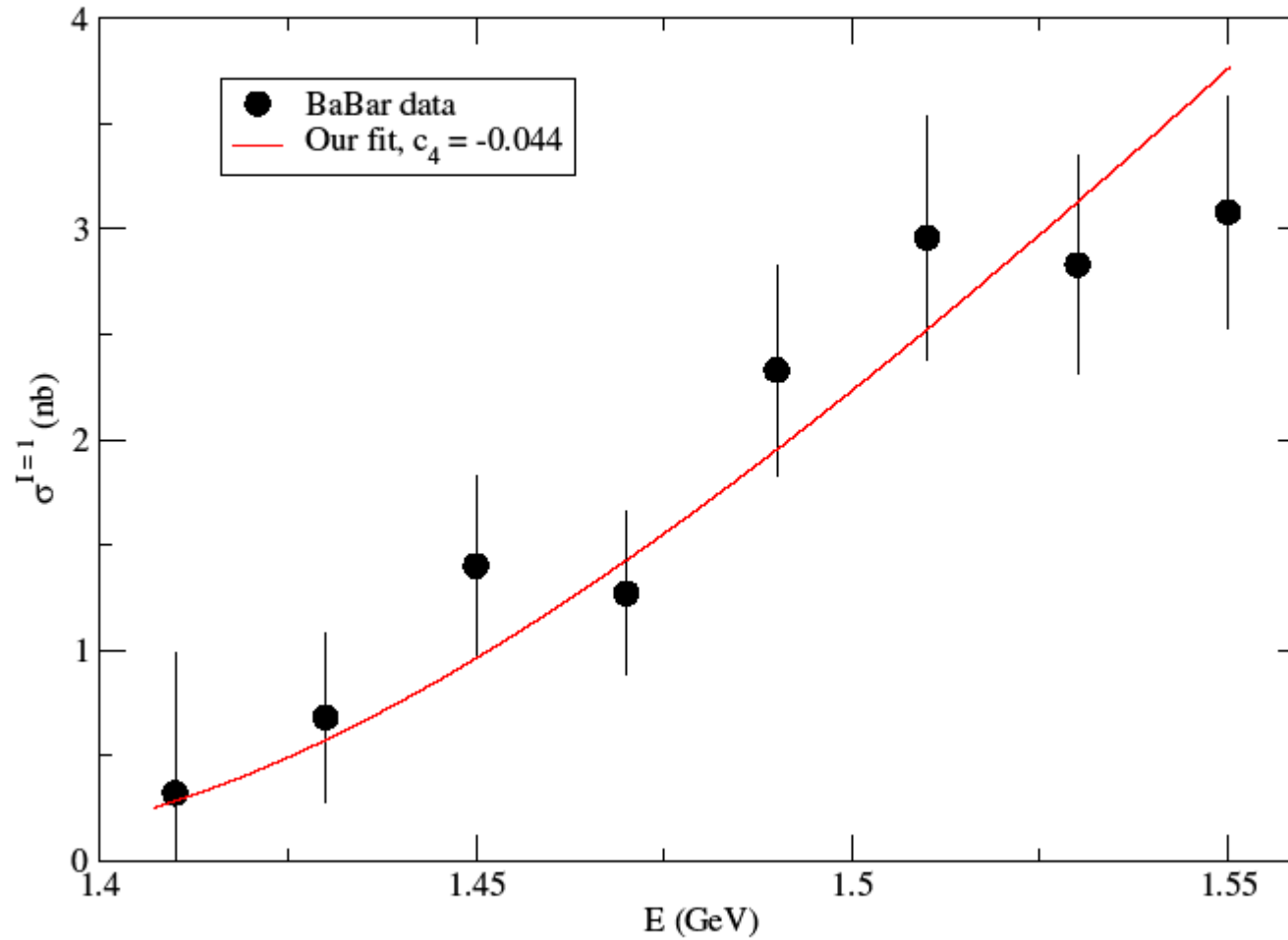

PREVIOUS WORK : $\tau^- \rightarrow (\pi \pi \pi)^- \nu_\tau$

Procedure and results [Gómez Dumm, Pich, Portolés, 2004]

Fit to the spectrum and BR
[ALEPH, 1998] $\tau^- \rightarrow \pi^- \pi^- \pi^+ \nu_\tau$

input

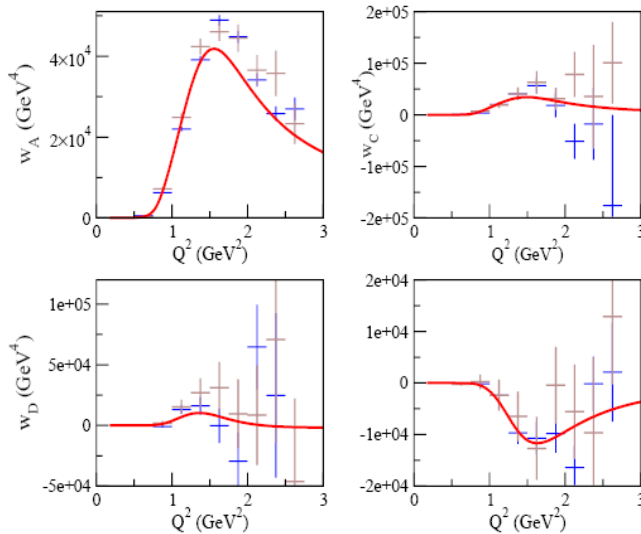
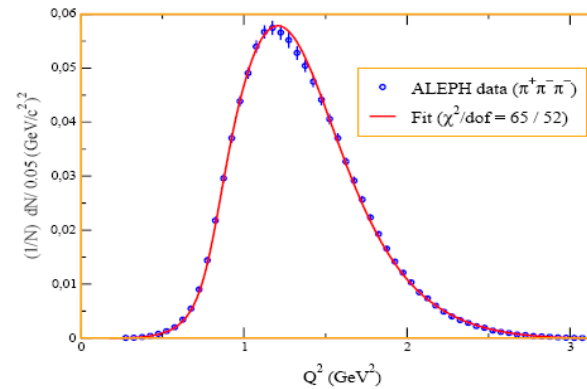

[CLEO-II,2000,(blue)] [OPAL,1997,(grey)]

output

$\tau^- \rightarrow \pi^- \pi^0 \pi^0 \nu_\tau$

Structure Functions

PDG06

$M_{a_1} = (1.204 \pm 0.007) \text{ GeV}$
 $\Gamma_{a_1}(M_{a_1}) = (0.48 \pm 0.02) \text{ GeV}$

$\lambda_0 = 11.9 \pm 0.4$

Implemented in SHERPA

IFIC - Instituto de Fisica Corpuscular

HADRONIZATION OF QCD CURRENTS
 Pablo Roig (IFIC)

QCD 08 Montpellier

$$\tau^- \rightarrow (\pi^+ \pi^- \pi^0) \nu_\tau$$

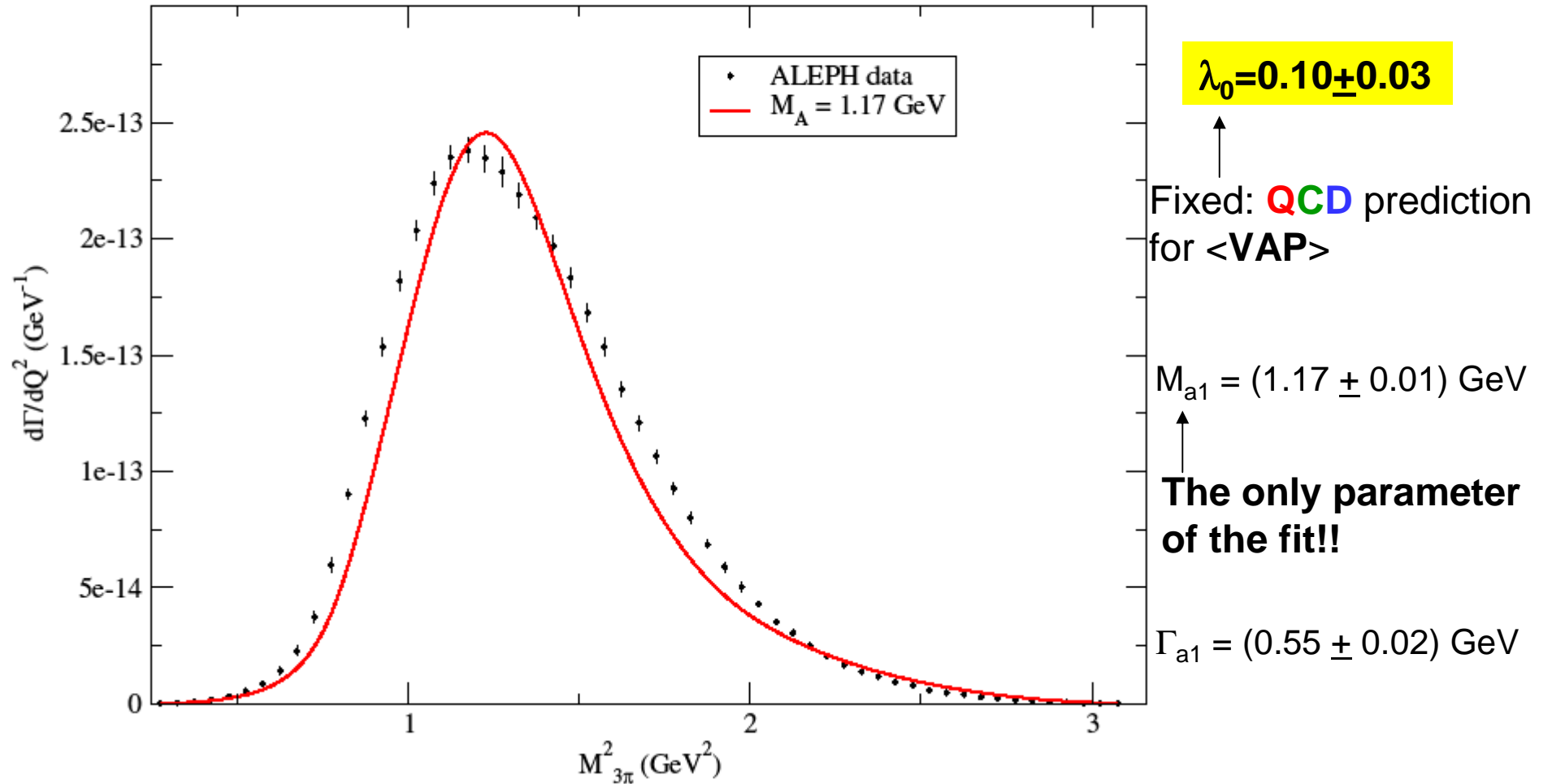

HADRONIZATION OF QCD CURRENTS

Pablo Roig (IFIC)

QCD 08 Montpellier

OFF-SHELL WIDTH OF MESON RESONANCES

$$\Gamma_{\rho}(s) = \frac{M_{\rho} s}{96\pi F^2} \left[\sigma_{\pi}^3 \Theta(s - 4m_{\pi}^2) + \frac{1}{2} \sigma_K^3 \Theta(s - 4m_K^2) \right]$$

$$\Gamma_{a_1}(Q^2) = \Gamma_{a_1}^{3\pi}(Q^2) + \Gamma_{a_1}^{K\bar{K}\pi}(Q^2) + \Gamma_{a_1}^{(K\pi)^0 K^0}(Q^2),$$

$$\Gamma_{a_1}^{3\pi}(Q^2) = \frac{1}{48(2\pi)^3 M_{a_1}} \left(\frac{Q^2}{M_{a_1}^2} \right) \iint ds dt (F_1' V_{1\mu} + F_2' V_{2\mu}).$$

$$(F_1'^{\dagger} V_{1\mu} + F_2'^{\dagger} V_{2\mu}), \quad F_i' = F_i \frac{M_{a_1}^2 - Q^2}{\sqrt{2} F_A Q^2}$$

OUTLOOK: $\tau^- \rightarrow (\underline{h_1} \underline{h_2} \underline{h_3})^- \nu_\tau$

$h_1 h_2 h_3$	F_A	F_V	
3π	✓		
$2K \pi$	✓	✓	
$K 2\pi$	✓	✓	$\rightarrow V_{us}, m_s$
$2\pi \eta$		✓	
$\pi K \eta$	✓	✓	$\rightarrow V_{us}, m_s$
$3K$	✓	✓	$\rightarrow V_{us}, m_s \rightarrow m_{V_\tau}$